

# Rk-5700 Series Power Meter



- **pW to kW; UV to Far-IR**
- **Single and Dual Channel**
- **Synchronous Detection**
- **GPIB Computer Interface**

The Rk-5700 Series Power Meters accept a wide variety of probes - pyroelectric, silicon, and thermopile - enabling them to perform absolute radiometry, total laser power (cw and average), and irradiance measurements from the UV to far-IR, pW to kW. Integrated lock-in amplifier circuitry allows for synchronous detection of chopped optical signals, improving both S/N ratio and background rejection. The dual channel Rk-5720 simultaneously measures Channel A, Channel B, and the ratio B/A. An IEEE-488 GPIB computer interface, Analog Outputs, Background Cancel, and Autorange are all standard features.

The Rk-5700 Series Power Meters feature a high-contrast, backlit, alphanumeric LCD display, dual-use numeric/function keys, and power switch. The Rk-5710 single channel instrument continuously shows the Channel A power in engineering notation, along with a digital bargraph. An enunciator indicates whether the instrument is in local or remote (GPIB enabled) mode. In addition, the Rk-5720 dual channel instrument shows the Channel B power in engineering notation and the B/A ratio. The power can be displayed in absolute units (Watts) or relative units (dBm).

Connecting an RkP-500 Series probe and optical chopper to an Rk-5700 Power Meter activates the synchronous detection feature. Synchronous detection requires two signals, an optical signal and an electrical reference signal. The optical signal is generated by light striking the RkP-500 Series probe after it has passed through the optical chopper. The chopper itself generates the reference signal. The advantage of synchronous detection is that the instrument will selectively measure only the optical signal with the same frequency as the reference signal, and ignore all other optical signals. By positioning the chopper so that only the desired optical source is chopped virtually all background

**LaserProbe** inc.

noise can be eliminated, insuring maximum S/N ratio. With this technique it is possible to measure a signal level that is smaller than the background.

The Background Cancel function is particularly useful for non-chopped probes that cannot take advantage of synchronous detection. When enabled it measures and stores the background power level, then subtracts it from all subsequent measurements leaving only the source power to be displayed.

Other useful functions include Autorange, which allows the instrument to automatically track a signal that is fluctuating over a wide power range. Fast Averaging sets the low-pass filter time constant to 1 second for more stable sources; Slow Averaging (10 sec) integrates over a longer period to give a better measure of the average power for a noisier source. Calibration Factors (one per channel) can be entered to compensate for non-linearity in the optical path, such as transmission loss through a filter or the wavelength response of a non-flat probe. The measured power is divided by the Calibration Factor and the corrected power is displayed.

Rear panel connectors for the Rk-5710 include the power entry module, Probe A, GPIB, Sync In, and Analog Out. The Rk-5720 also has Probe B, A Out and B Out, and replaces Analog Out with Ratio Out. The power entry module accepts a standard line cord and has a switchable 110/220 VAC card. The Sync In accepts a TTL reference signal for synchronizing the instrument to an external chopper (30 Hz, 50% duty cycle, 180° out of phase with the chopped optical signal).

Analog Out, A Out, and B Out are 0 - 10 VDC, with 10 V corresponding to full scale in both linear (Watts) and logarithmic (dBm) mode. In linear mode the Ratio Out is 0-10 VDC where the voltage equals the mantissa; in log mode it is -10 V to +10 V, representing -100 dBm to +100 dBm. The IEEE-488 GPIB computer interface outputs in ASCII format the power in Watts (engineering notation) or dBm. For the Rk-5720 the Ratio B/A is also available in linear (scientific notation) or logarithmic (dB) format. All outputs update with the front panel display at 3 Hz.

The Rk-5700 Series instruments are compatible with the RkP-500 and RkT Series probes. Contact the factory for additional information regarding probe compatibility and available options.

The Rk-5700 Series instruments are provided with a certificate of calibration showing traceability to the National Institute of Standards and Technology (NIST) and compliance with MIL-45662 and ANSI-Z540 Sections 7-18.

Resolution	0.005% of F.S. (RkP-500 Series) 0.03% of F.S. (all other probes)
Ratio range	10 <sup>15</sup> to 1 (probe dependent)
Ratio accuracy	± 2 LSD
Calibration factor	0.100 to 1.000
Response time	1.0 sec, 10 sec
Background subtract	Up to P <sub>max</sub> of probe
Chopping frequency	30 Hz ± 0.1 Hz; 50% duty cycle
Accuracy	± 0.5%
Analog Out, A Out, and B Out	0 - 10 VDC, 10 V equals F.S. for linear (Watts) and logarithmic (dBm) mode
Ratio Out	0 - 10 VDC, proportional to mantissa or -10 to +10 VDC, proportional to -100 to +100 dBm
GPIB	Talker/Listener; Address 0-30; Terminator LF/CR
Power supply	120/240 ±10% VAC; 50-60 Hz
Temperature range	0°C to 40°C operating; -20°C to 70°C storage
Dimensions (l x w x h)	30.6 cm x 26.3 cm x 10.1 cm (12.1" x 10.4" x 4.0")
Weight	4.1 kg (9.0 lb)

SPECIFICATIONS

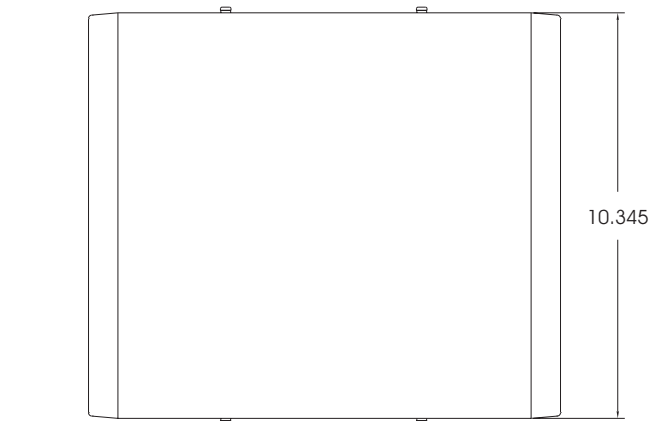
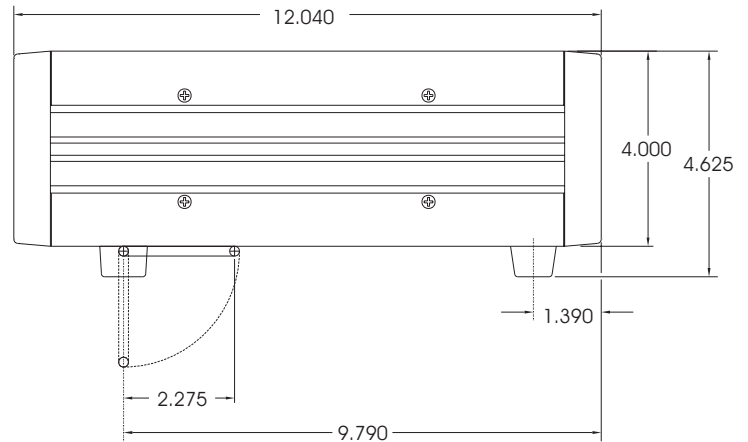

As a result of our ongoing commitment to product improvement specifications are subject to change without notice. REV 019801js